

# Stretch Wrapping System With Rotating Platform



## WHY INKA?

EFFICIENT

STABLE PALLET

LOW CONSUMPTION

DETAILED CONTROL FEATURES

The system offers low consumption of stretch film. The pallet can be wrapped with the load which makes the load much more stable without the need of any additional equipment. Thanks to its detailed settings from the screen, rotation speed, tension, wrapping cycle are adjustable on any location of the load. Also corner tension relief setting is available preventing the load being damaged. Roping feature is added during standart wrapping which enables the load more stable. Its robust structure ensures a system that can be used for many years.

## Dimensions

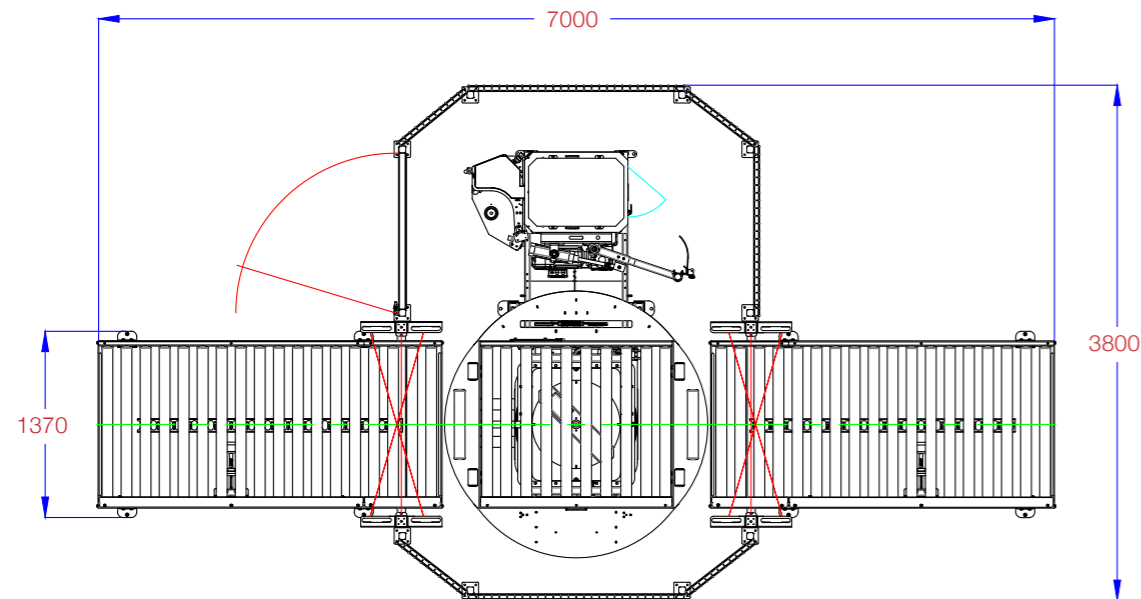

## Screen Views



Main screen of the system, when the system is operating necessary info can be followed from here.

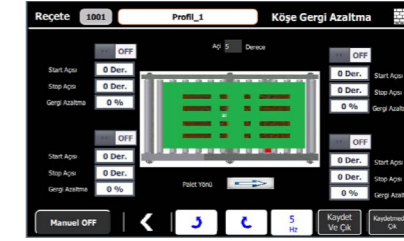

Additional stretch tension adjustments can be made for each pallet corner to prevent stretch breakage.

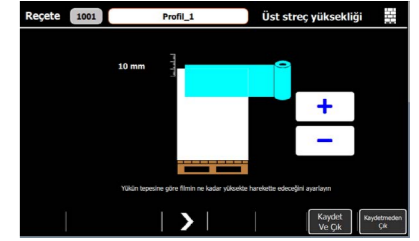

The dimension of stretch exceeding the load can be adjusted.

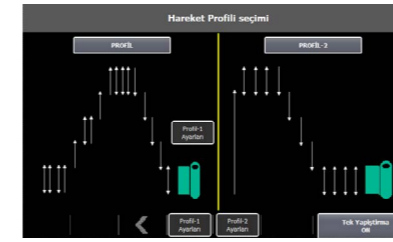

Wrapping scheme can be created in detail.

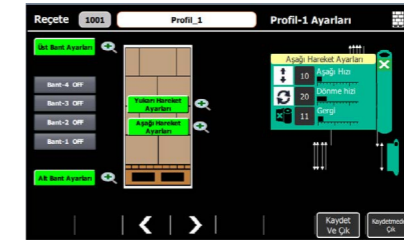

Wrapping speed and stretch tension can be adjusted via these controls.



Contains detailed controls and data on manual operation of the equipments.

## Technical Features

Description	Technical Data
Load Size - Max (mm)	1050 x 1400 x 2000
Load Size - Min (mm)	600 x 800 x 600
Load Height - Max (mm)	2000 (Higher than 2000 mm is manufactured upon request.)
Pallet Conveyor Height (mm)	400 - 500
Pallet Leading on Conveyor	Transversely
Pallet Weight - Max. (kg)	1500
Standart Pre-Stretch Ratio	% 225
Pre - Stretch Ratio - Min & Max	% 100 - % 300
Speed - Max (Pallets / Hour)	30
Control	VIPA Speed 7 PLC with Ethernet Communication
HMI	Siemens KTP 700 Touchscreen
Roping Unit	Standard
Pallet Wrapping with Load	Standard
Automatic Sealer	Optional
Program	Siemens Tia Portal
Installed Power (kW)	7
Power Requirements	3P+N+PE 380 V, 50/60 Hz.
Air Pressure (Bar)	6